



SUBMISSION TO THE NATIONAL TRANSPORT AUTHORITY

FROM IBUS PLC.





Vision Statement

Create a new network of passenger services for the Ireland of today linking it with the Ireland of tomorrow.

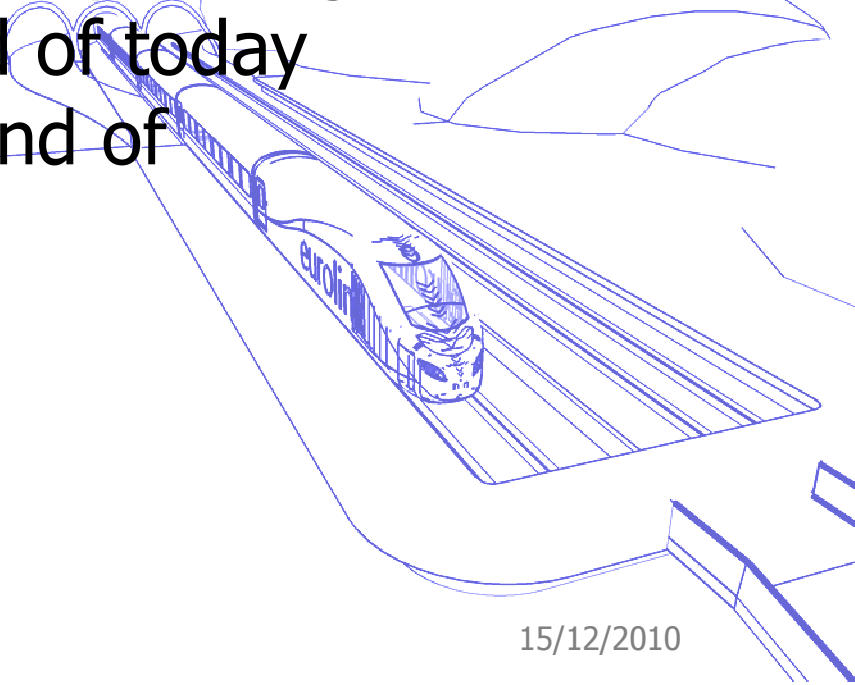

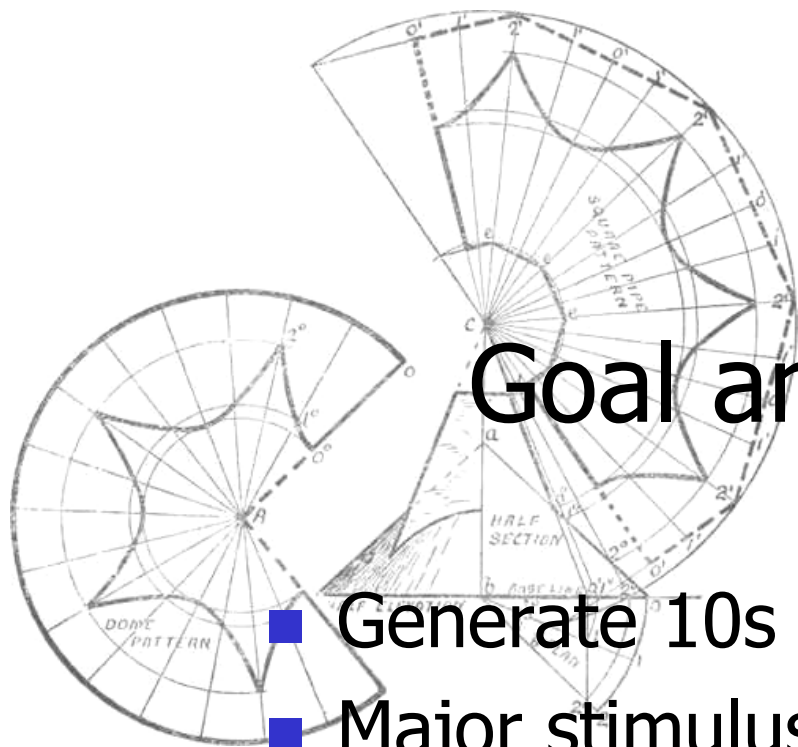

Goal and Objective

- Generate 10s of 1,000 of jobs
- Major stimulus to recovery
- Pivotal to Europe
- Use Irish natural resource
- Attract major EU funding

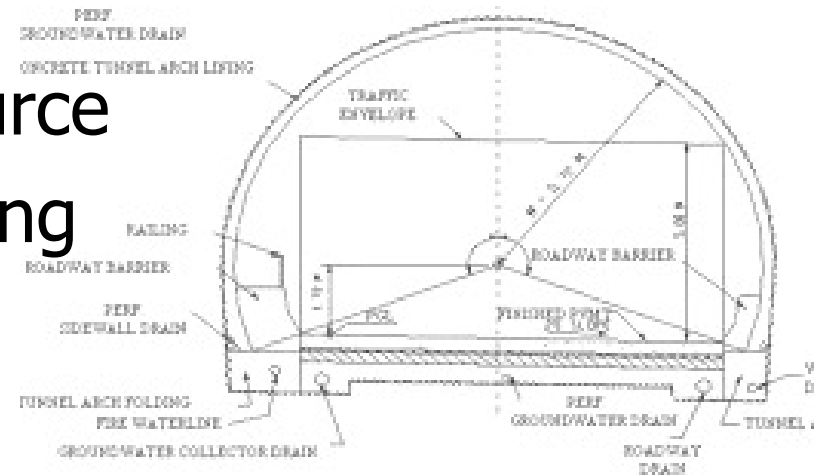

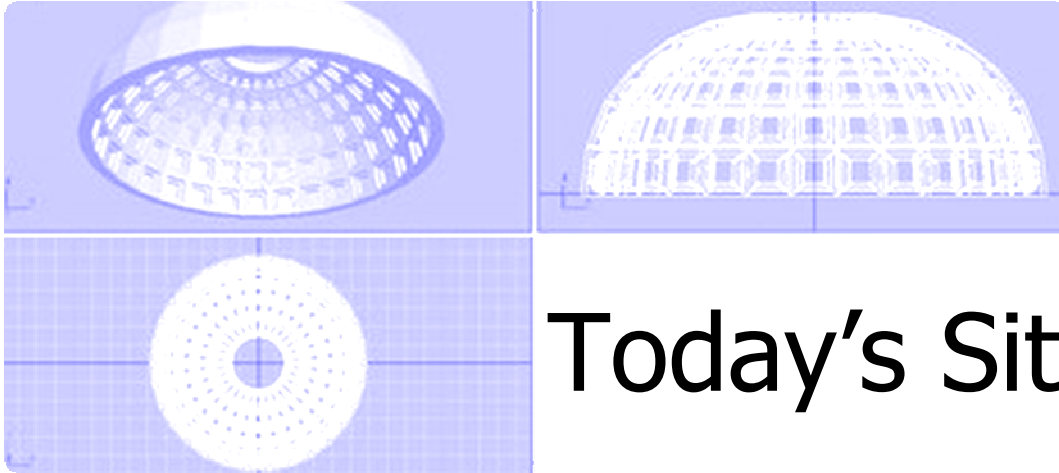

Today's Situation

- Limited access
- Limited financial resources
- Based on structures developed 75 years ago
- No competition
- No focal point





How Did We Get Here?

- Representational model ineffective
- Bus/Coach industry incapacity to deliver
- Protected status of existing routes
- Transport of last resort
- Dependence on State funding
- “cut the service” solution

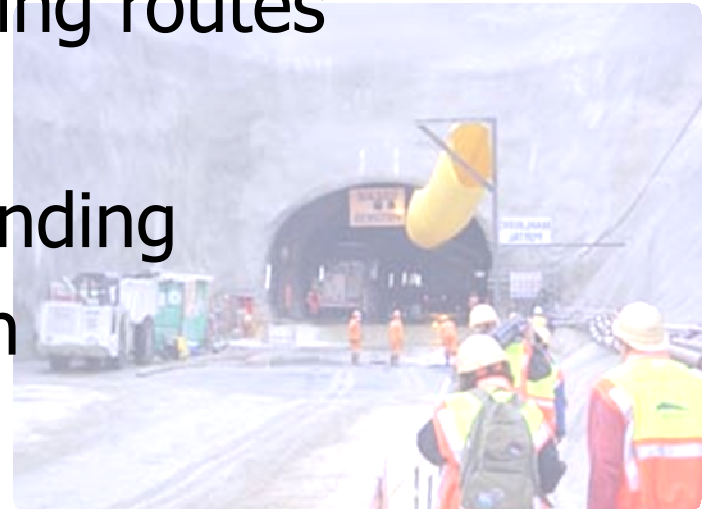



Available Options

Immediately:

- National Bus Terminus
- Additional National network of routes
- Identifiable cohesive private sector alternative
- No requirement for State funding

Longer Term:

- Connection to Europe via Cuchulann Tunnel*



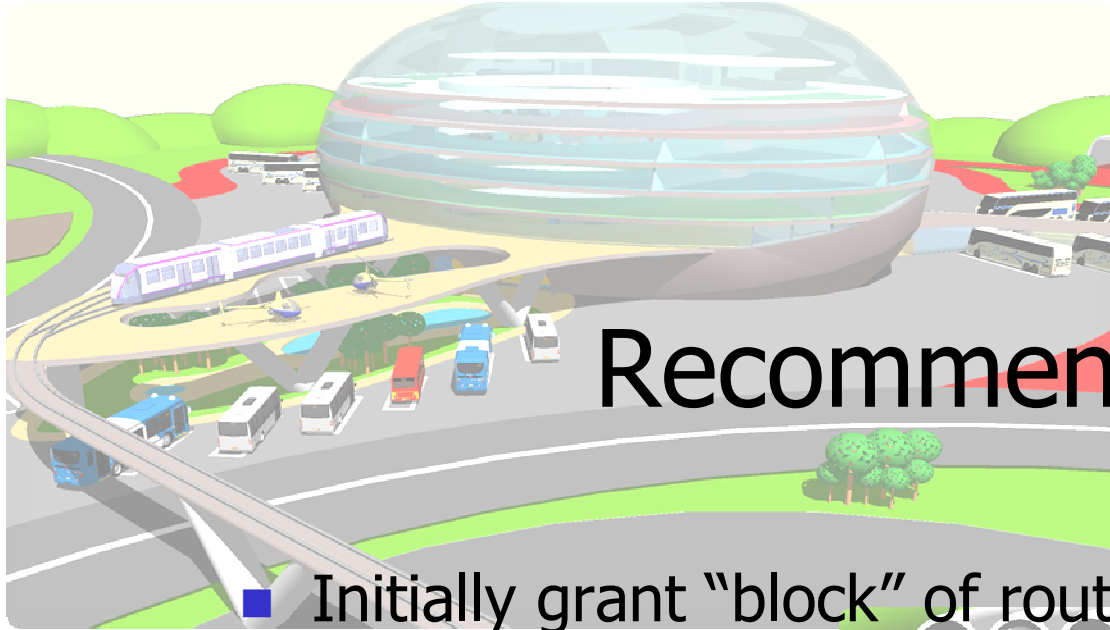

Recommendation

- Initially grant “block” of route licences to ibus plc. serving National Bus Terminus to include Cuchulann Tunnel*
- ibus plc. can source funding for National Bus Terminus
- Divert relevant existing routes to National Bus Terminus
- Act now!

